



Cell Extender

System Manual

August 2004
P/N 213837

Legal Rights

© Copyright 2004 Alvarion Ltd (“Alvarion”). All rights reserved.

The material contained herein is proprietary, privileged, and confidential. No disclosure thereof shall be made to third parties without the express written permission of Alvarion.

Alvarion reserves the right to alter the equipment specifications and descriptions in this publication without prior notice. No part of this publication shall be deemed to be part of any contract or warranty unless specifically incorporated by reference into such contract or warrant.

Trade Names

Alvarion, BreezeCOM, WALKair, WALKnet, BreezeNET, BreezeMANAGE, BreezeACCESS, BreezeLINK, BreezePHONE, MGW, eMGW and/or other products and/or services referenced here in are either registered trademarks, trademarks or service marks of Alvarion.

All other names are or may be the trademarks of their respective owners.

Statement of Conditions

The information contained in this manual is subject to change without notice. Alvarion shall not be liable for errors contained herein or for incidental or consequential damages in connection with the furnishing, performance, or use of this manual or equipment supplied with it.

Warranties and Disclaimers

All Alvarion products purchased from Alvarion or through any of Alvarion’s authorized resellers are subject to the following warranty and product liability terms and conditions.

Exclusive Warranty

Alvarion warrants that the Product hardware it supplies and the tangible media on which any software is installed, under normal use and conditions, will be free from significant defects in materials and workmanship for a period of fourteen (14) months from the date of shipment of a given Product to Purchaser (the “Warranty Period”). Alvarion will, at its sole option and as Purchaser’s sole remedy, repair or replace any defective Product in accordance with Alvarion’ standard RMA procedure.

Disclaimer

(a) UNITS OF PRODUCT (INCLUDING ALL THE SOFTWARE) DELIVERED TO PURCHASER HEREUNDER ARE NOT FAULT-TOLERANT AND ARE NOT DESIGNED, MANUFACTURED OR INTENDED FOR USE OR RESALE IN APPLICATIONS WHERE THE FAILURE, MALFUNCTION OR INACCURACY OF PRODUCTS CARRIES A RISK OF DEATH OR BODILY INJURY OR SEVERE PHYSICAL OR ENVIRONMENTAL DAMAGE (“HIGH RISK ACTIVITIES”). HIGH RISK ACTIVITIES MAY INCLUDE, BUT ARE NOT LIMITED TO, USE AS PART OF ON-LINE CONTROL SYSTEMS IN HAZARDOUS ENVIRONMENTS REQUIRING FAIL-SAFE PERFORMANCE, SUCH AS IN THE OPERATION OF NUCLEAR FACILITIES, AIRCRAFT NAVIGATION OR COMMUNICATION SYSTEMS, AIR TRAFFIC CONTROL, LIFE SUPPORT MACHINES, WEAPONS SYSTEMS OR OTHER APPLICATIONS REPRESENTING A SIMILAR DEGREE OF POTENTIAL HAZARD. ALVARION SPECIFICALLY DISCLAIMS ANY EXPRESS OR IMPLIED WARRANTY OF FITNESS FOR HIGH RISK ACTIVITIES.

(b) PURCHASER’S SOLE REMEDY FOR BREACH OF THE EXPRESS WARRANTIES ABOVE SHALL BE REPLACEMENT OR REFUND OF THE PURCHASE PRICE AS SPECIFIED ABOVE, AT ALVARION’S OPTION. TO THE FULLEST EXTENT ALLOWED BY LAW, THE WARRANTIES AND REMEDIES SET FORTH IN THIS AGREEMENT ARE EXCLUSIVE AND IN LIEU OF ALL OTHER WARRANTIES OR CONDITIONS, EXPRESS OR IMPLIED, EITHER IN FACT OR BY OPERATION OF LAW, STATUTORY OR OTHERWISE, INCLUDING BUT NOT LIMITED TO WARRANTIES, TERMS OR CONDITIONS OF MERCHANTABILITY, FITNESS FOR A PARTICULAR PURPOSE, SATISFACTORY QUALITY, CORRESPONDENCE WITH DESCRIPTION, NON-INFRINGEMENT, AND ACCURACY OF INFORMATION GENERATED. ALL OF WHICH ARE EXPRESSLY DISCLAIMED. ALVARION’S WARRANTIES HEREIN RUN ONLY TO PURCHASER, AND ARE NOT EXTENDED TO ANY THIRD PARTIES. ALVARION NEITHER ASSUMES NOR AUTHORIZES ANY OTHER PERSON TO ASSUME FOR IT ANY OTHER LIABILITY IN CONNECTION WITH THE SALE, INSTALLATION, MAINTENANCE OR USE OF ITS PRODUCTS.

(c) ALVARION SHALL NOT BE LIABLE UNDER THIS WARRANTY IF ITS TESTING AND EXAMINATION DISCLOSE THAT THE ALLEGED DEFECT IN THE PRODUCT DOES NOT EXIST OR WAS CAUSED BY PURCHASER'S OR ANY THIRD PERSON'S MISUSE, NEGLIGENCE, IMPROPER INSTALLATION OR IMPROPER TESTING, UNAUTHORIZED ATTEMPTS TO REPAIR, OR ANY OTHER CAUSE BEYOND THE RANGE OF THE INTENDED USE, OR BY ACCIDENT, FIRE, LIGHTNING OR OTHER HAZARD.

Limitation of Liability

(a) ALVARION SHALL NOT BE LIABLE TO THE PURCHASER OR TO ANY THIRD PARTY, FOR ANY LOSS OF PROFITS, LOSS OF USE, INTERRUPTION OF BUSINESS OR FOR ANY INDIRECT, SPECIAL, INCIDENTAL, PUNITIVE OR CONSEQUENTIAL DAMAGES OF ANY KIND, WHETHER ARISING UNDER BREACH OF CONTRACT, TORT (INCLUDING NEGLIGENCE), STRICT LIABILITY OR OTHERWISE AND WHETHER BASED ON THIS AGREEMENT OR OTHERWISE, EVEN IF ADVISED OF THE POSSIBILITY OF SUCH DAMAGES.

(b) TO THE EXTENT PERMITTED BY APPLICABLE LAW, IN NO EVENT SHALL THE LIABILITY FOR DAMAGES HEREUNDER OF ALVARION OR ITS EMPLOYEES OR AGENTS EXCEED THE PURCHASE PRICE PAID FOR THE PRODUCT BY PURCHASER, NOR SHALL THE AGGREGATE LIABILITY FOR DAMAGES TO ALL PARTIES REGARDING ANY PRODUCT EXCEED THE PURCHASE PRICE PAID FOR THAT PRODUCT BY THAT PARTY (EXCEPT IN THE CASE OF A BREACH OF A PARTY'S CONFIDENTIALITY OBLIGATIONS).

Electronic Emission Notices

This device complies with Part 15 of the FCC rules.

Operation is subject to the following two conditions:

1. This device may not cause harmful interference.
2. This device must accept any interference received, including interference that may cause undesired operation.

The devices operating in the 2.4 GHz band have been certified under two FCC ID Grants, one when operating in Frequency Hopping (FH) mode and another when operating in Hybrid Digital Modulation (HDM) mode. Refer to the Setting Basic Parameters in 2.4 GHz Units section in this manual for proper unit configuration when operating in each of these modes.

FCC Radio Frequency Interference Statement

The Cell Extender equipment has been tested and found to comply with the limits for a class A digital device, pursuant to Part 15 of the FCC rules and EN300385 rules. These limits are designed to provide reasonable protection against harmful interference when the equipment is operated in commercial, business and industrial environments. This equipment generates, uses, and can radiate radio frequency energy and, if not installed and used in accordance with the instruction manual, may cause harmful interference to radio communications. Operation of this equipment in a residential area is likely to cause harmful interference in which case the user will be required to correct the interference at the user's own expense.

FCC Radiation Hazard Warning

To comply with FCC RF exposure requirement, the antenna used for this transmitter must be fixed-mounted on outdoor permanent structures with a separation distance of at least 2 meter from all persons and must not be co-located or operating in conjunction with any other antenna or transmitter.

R&TTE Compliance Statement

This equipment complies with the appropriate essential requirements of Article 3 of the R&TTE Directive 1999/5/EC.

Safety Considerations

For the following safety considerations, "Instrument" means the Cell Extender components and their cables.

Caution

To avoid electrical shock, do not perform any servicing unless you are qualified to do so.

Line Voltage

Before connecting this instrument to the power line, make sure that the voltage of the power source matches the requirements of the instrument.

Installation Codes

The system must be installed according to country national electrical codes. For North America, equipment must be installed in accordance to the US National Electrical Code (NEC) Articles 110-16, 110-17 and 110-18 and the Canadian Electrical Code (CEC), Sections 2-202 and 2-308. Wiring methods are to be in accordance to NEC Article 300 and CEC Section 12.

Over-Current Protection

A readily accessible external Listed branch circuit over-current protective device rated 15 A must be provided.

Radio

The instrument transmits radio energy during normal operation. To avoid possible harmful exposure to this energy, do not stand or work for extended periods of time in front of its antenna. The long term characteristics or the possible physiological effects of Radio Frequency Electromagnetic fields have not been yet fully investigated.

Outdoor Unit and Antenna Installation and Grounding

Be sure that the outdoors units, the antenna and the supporting structure are properly installed to eliminate any physical hazard to either people or property. Verify that the outdoors units and the antenna mast (when using external antenna) are grounded so as to provide protection against voltage surges and static charges. Alvarion offers an installation kit which contains a mounting arm and grounding hardware. Two kits are required for the two radio units of the Cell Extender. Make sure that the installation of the outdoor unit, antenna and cables is performed in accordance with all relevant national and local building and safety codes.

Important Notice

This user manual is delivered subject to the following conditions and restrictions:

- This manual contains proprietary information belonging to Alvarion. Such information is supplied solely for the purpose of assisting properly authorized users of the respective Alvarion products.
- No part of its contents may be used for any other purpose, disclosed to any person or firm or reproduced by any means, electronic and mechanical, without the express prior written permission of Alvarion.
- The text and graphics are for the purpose of illustration and reference only. The specifications on which they are based are subject to change without notice.
- The software described in this document is furnished under a license. The software may be used or copied only in accordance with the terms of that license.
- Information in this document is subject to change without notice. Corporate and individual names and data used in examples herein are fictitious unless otherwise noted.
- Alvarion reserves the right to alter the equipment specifications and descriptions in this publication without prior notice. No part of this publication shall be deemed to be part of any contract or warranty unless specifically incorporated by reference into such contract or warranty.
- The information contained herein is merely descriptive in nature, and does not constitute an offer for the sale of the product described herein.
- Any changes or modifications of equipment, including opening of the equipment not expressly approved by Alvarion will void equipment warranty and any repair thereafter shall be charged for. It could also void the user's authority to operate the equipment.

- Some of the equipment provided by Alvarion and specified in this manual, is manufactured and warranted by third parties. All such equipment must be installed and handled in full compliance with the instructions provided by such manufacturers as attached to this manual or provided thereafter by Alvarion or the manufacturers. Non-compliance with such instructions may result in serious damage and/or bodily harm and/or void the user's authority to operate the equipment and/or revoke the warranty provided by such manufacturer.



About this Guide



This manual introduces the BreezeACCESS Cell Extender and provides a detailed description of the system components. In addition, this guide describes how to install, initialize and operate the Cell Extender.

This guide is intended for technicians responsible for installing, setting-up and operating the Cell Extender.

This guide comprises the following chapters:

- **Chapter 1– Introduction:** Describes the Cell Extender and its components.
- **Chapter 2 – Installation:** Describes how to install Cell Extender components.
- **Chapter 3 – Commissioning:** Describes how to configure basic parameters, align the Subscriber Unit antenna and validate unit operation.
- **Appendix A - Wiring 10/100Base-T jacks:** Describes standard 10/100Base-T wiring schemes.
- **Appendix B – Preparing the indoor to outdoor Ethernet cable:** Provides details on preparation of the indoor to outdoor Ethernet cable.
- **Appendix C – CX-BA2.4-BA2.4 and CX-BA2.4-BA900 Mechanical Structure of Interface Units:** Describes the difference between current mechanical design of the Interface Units of CX-BA2.4-BA2.4 and CX-BA2.4-BA900 and other Cell Extenders' Interface Units as described in this manual.

This guide is applicable for BreezeACCESS II (2.4 GHz) and BreezeACCESS 900 units running SW version 4.5, and for BreezeACCESS VL units running SW version 2.0.



Contents

Chapter 1 - System Description.....1-1

Introducing the Cell Extender 1-2

Specifications 1-5

2.4 GHz Radio specifications	1-5
BreezeACCESS VL Radio specifications	1-6
900 MHz Radio specifications.....	1-7
Standards Compliance, General	1-9
Mechanical.....	1-10
Electrical.....	1-10
Connectors.....	1-11
Environmental	1-11

Chapter 2 - Installation2-1

Installation Requirements..... 2-2

Packing List for CX-BA2.4-BA2.4 Cell Extender.....	2-2
Packing List for CX-BA2.4-BA900 Cell Extender	2-2
Packing List for CX-VLA.B*-BA2.4 Cell Extender	2-3
Packing List for CX-VLA.B*-BA900 Cell Extender	2-3
Additional Items Required for the CX Installation	2-4
Equipment Location Guidelines.....	2-5
IF Cables	2-5
Approved Antennas	2-6
Installing the Radio Units.....	2-8
Pole Mounting the Radio Unit.....	2-8
Connecting the Cables.....	2-10
Installing the AU's Antenna	2-12
Installing the CX-IDU Interface Unit.....	2-13
Wall Mounting the Interface Unit.....	2-15
Poll Mounting the Interface Unit.....	2-16
Preparing the Power Cord	2-17
Connecting the Cables.....	2-18

Chapter 3 - Commissioning	3-1
Configuring Basic Parameters.....	3-2
Accessing the Monitor Program.....	3-2
The Basic Parameters	3-5
Basic Parameters in 2.4 GHz Units (SW Version 4.5).....	3-6
Basic Parameters in 900 MHz Units (SW version 4.5)	3-10
Basic Parameters in BreezeACCESS VL SU (SW Version 2.0).....	3-12
Aligning the SU's Antenna.....	3-14
Configuring the Transmit Power of the AU-RE-2.4	3-16
Verifying Proper Operation.....	3-17
LED Indicators.....	3-17
Appendix A - Wiring 10/100Base-T Jacks	A-1
Connecting a PC to the CX.....	A-2
Connecting a Hub to the CX	A-2
Appendix B - Preparing the Indoor to Outdoor Ethernet Cable	B-1
Appendix C - Mechanical Structure and Installation of CX-IDU units Currently supplied with CX-BA2.4-BA-2.4 and CX-BA2.4-BA900	C-1
Mechanical and Environmental Specifications	C-2
Installation	C-2

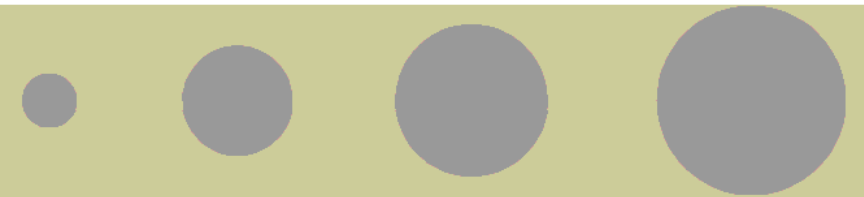

Figures

Figure 2-1: Threaded Holes/Grooves.....	2-8
Figure 2-2: 3" Pole Installation of the Radio Unit Using Special Brackets	2-9
Figure 2-3: SU-RA-2.4 Bottom Panel.....	2-10
Figure 2-4: AU-RE-2.4, AU-RE-900 Bottom Panel	2-10
Figure 2-5: BreezeACCESS VL ODU Bottom Panel (without the service box)....	2-11
Figure 2-6: Interface Unit Bottom Panel.....	2-13
Figure 2-7: Wall Mounting the Interface Unit	2-15
Figure 2-8: Interface Unit with Sun Guard.....	2-15
Figure 2-9: Pole Mounting the Indoor Unit	2-16
Figure 2-10: Preparing the Power Cord	2-17
Figure 3-1: Set IP Window.....	3-4
Figure A-1: Straight-Through Cable Connection.....	A-2
Figure A-2: Crossover Cable Connections	A-2
Figure B-1: Ethernet Connector Pin Assignments.....	B-2
Figure C-1: Interface Unit Bottom Panel.....	C-2
Figure C-2: Wall Mounting the Interface Unit.....	C-3
Figure C-3: Interface Unit with Sun Guard.....	C-3





Tables

Table 1-1: Cell Extender Models –Product Families/Bands.....	1-3
Table 1-2: Cell Extender Models –Radio Units	1-3
Table 1-3: 2.4 GHz Radio Specifications.....	1-5
Table 1-4: BreezeACCESS VL Radio Specifications	1-6
Table 1-5: Maximum Output Power at Antenna Port (dBm)	1-7
Table 1-6: 900 MHz Radio Specifications.....	1-7
Table 1-7: Standards Compliance, General	1-9
Table 1-8: Mechanical Specifications.....	1-10
Table 1-9: Electrical Specifications.....	1-10
Table 1-10: Connectors	1-11
Table 1-11: Environmental Specifications	1-11
Table 2-1: IF Cables	2-6
Table 2-2: 2.4 GHz FCC Approved Antenna.....	2-6
Table 2-3: 900 MHz AU FCC Approved Antenna.....	2-7
Table 2-4: CX-IDU’s Connectors.....	2-14
Table 3-1: Monitor Port Communication Parameters	3-3
Table 3-2: Maximum Output Power for IC&FCC Compliance.....	3-6
Table 3-3: Basic Parameters in 2.4 GHz Units.....	3-6
Table 3-4: Basic Parameters in 900 MHz AUs	3-10
Table 3-5: Basic Parameters in BreezeACCESS VL SU.....	3-12
Table 3-6: Required Value of Transmit Power Control Parameter for 2.4 GHz FCC Approved AU Antennas.....	3-16
Table 3-7: SU-RA-2.4 LEDs.....	3-17

Tables

Table 3-8: AU-RE-2.4, AU-RE-900 LEDs.....3-17

Table 3-9: BreezeACCESS VL SU-ODU LEDs.....3-18

Table B-1: Cable Color Codes B-2

Table 3-2: Mechanical and Environmental Specifications C-2





1

Chapter 1 - System Description

In this Chapter

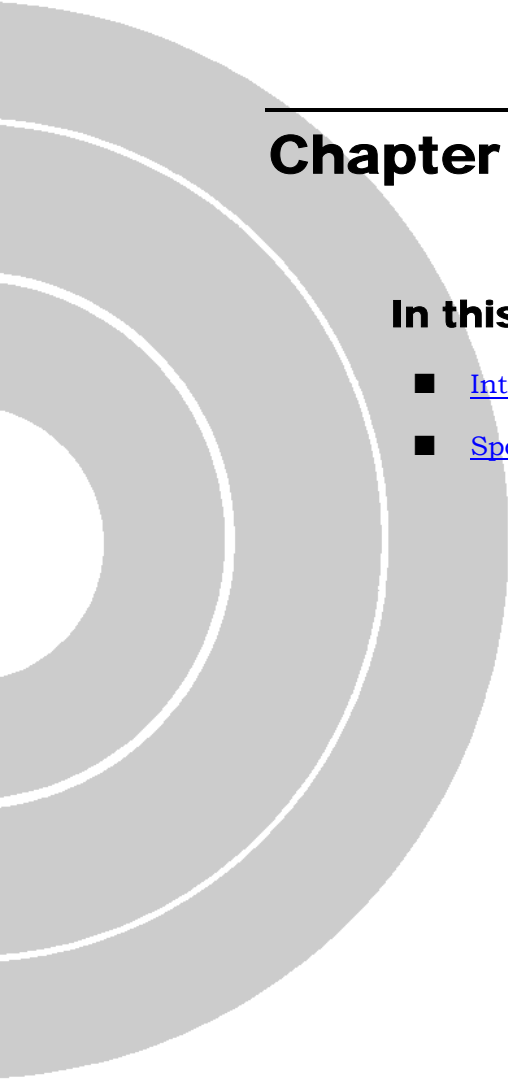
- [Introducing the Cell Extender](#), on page 1-2
 - [Specifications](#), on page 1-5
- 

Introducing the Cell Extender

The Cell Extender extends the reach of the system providing coverage to areas that cannot otherwise be reached economically due to obstacles or range limitations. In addition, the Cell Extender can be used to serve small remote clusters of subscribers where subscriber density or other economic factors do not warrant a completely separate cell.

Cell Extenders that operate in mixed radio bands offers additional benefits: Operators that typically provide services using the 2.4 GHz or 5 GHz band, can benefit from the advantage of operating locally in the 900 MHz band, being able to provide services to customers within a radius of half a mile in non line of sight environments with heavy foliage.

The Cell Extender operates as an Access and Subscriber Unit that are connected back-to-back. The Subscriber Unit component provides connectivity to the primary base station. The Access Unit component serves the Subscriber Units located in the area covered by the Cell Extender.

The Cell Extender is comprised of an Interface Unit and two Radio Units.

The Interface Unit includes the interface (indoor) units of both an Access and Subscriber Unit connected to each other via a hub module. It provides an interface for an optional local Ethernet connection and is powered from the mains (110/220VAC).

The radio unit of the Subscriber Unit component incorporates an integrated flat antenna.

The radio unit of the Access Unit component incorporates an RF connection to an antenna.

The following tables provide details on the product line, frequency band and types of radio unit applicable for each of the currently available models of the Cell Extender:

Model	SU's outdoor unit	AU's outdoor unit
CX-BA2.4-BA2.4	BreezeACCESS II/2.4 GHz	BreezeACCESS II/2.4 GHz
CX-BA2.4-BA900	BreezeACCESS II/2.4 GHz	BreezeACCESS 900/900 MHz
CX-VLA.B*-BA2.4	BreezeACCESS VL/A.B* GHz	BreezeACCESS II/2.4 GHz
CX-VLA.B* -BA900	BreezeACCESS VL/A.B* GHz	BreezeACCESS 900/900 MHz

* A.B is the radio band of the BreezeACCESS VL unit. BreezeACCESS VL products are currently available in the 5.8 GHz band.

NOTE **Applicable to CX-BA2.4-BA2.4 and CX-BA2.4-BA900**



The mechanical structure of current Interface Units of CX-BA2.4-BA2.4 and CX-BA2.4-BA900 is slightly different from the mechanical structure of Interface Units of other Cell Extenders as described throughout the manual. Refer to Appendix C for more details on the applicable differences.

Model	SU's outdoor unit	AU's outdoor unit
CX-BA2.4-BA2.4	SU-RA-2.4	AU-RE-2.4
CX-BA2.4-BA900	SU-RA-2.4	AU-RE-900
CX-VLA.B*-BA2.4	SU-A-A.B*-ODU	AU-RE-2.4
CX-VLA.B*-BA900	SU-A-A.B*-ODU	AU-RE-900

* A.B is the radio band of the BreezeACCESS VL unit. BreezeACCESS VL products are currently available in the 5.8 GHz band.

The Interface Unit is connected to radio units operating in the 2.4 GHz or 900 MHz band via a TNC connector and 50 ohm coaxial Intermediate Frequency (IF) cable. This cable carries 440 MHz IF signals between the Interface Unit and the radio unit. In addition, this cable transfers power (12 VDC) and control signals from the Interface Unit to the radio units.

The connection to a BreezeACCESS VL outdoor unit is via a weather protected Ethernet connector and a Category 5 Ethernet cables. This cable carries Ethernet traffic between the indoor and the outdoor units, and also transfers power (54 VDC) and control from the indoor unit to the outdoor unit.

Specifications

2.4 GHz Radio specifications

Table 1-3: 2.4 GHz Radio Specifications		
Item	Description	
Frequency	2.4000 – 2.4835 GHz ISM band	
Operation Mode	Time Division Duplex (TDD)	
Radio Access Method	FH-CDMA	
Standard Compliance	FCC Part 15.247	
Channel Bandwidth	1 MHz	
Central Frequency Resolution	1 MHz	
SU-RA Integral Antenna	16dBi, 20° horizontal x 20° vertical, VPOL, EN 301 525 Class TS 2 compliant	
Maximum Input Power (at antenna port)	-20dBm	
Output Power (at antenna port)	26dBm typical Control Range 20dB typical	
Gross Bit Rate	1, 2, 3 Mbps	
Sensitivity, typical (dBm at antenna port, BER 10E-6)	<u>Gross Rate</u>	<u>Sensitivity</u>
	1 Mbps	-87dBm
	2 Mbps	-81dBm
	3 Mbps	-73dBm
Modulation	GFSK modulation, 2, 4 8 modulation states (1, 2, 3 bits/symbol)	
Symbol Rate	1 Msymbol/sec	

BreezeACCESS VL Radio specifications

Item	Description			
Frequency	5.8 GHz Family: 5.725 – 5.850 GHz			
Operation Mode	Time Division Duplex (TDD)			
Channel Bandwidth	20 MHz			
Central Frequency Resolution	10 MHz			
SU-A-ODU Integral Antenna	21dBi, 5.150-5.875 GHz, 10.5° horizontal x 10.5° vertical, vertical polarization, compliant with EN 302 085 V1.1.1 Range 1, Class TS 1, 2, 3, 4, 5			
Max. Input Power (at antenna port)	HW Rev. A: -48dBm typical HW Rev. B: -30dBm typical			
Output Power (at antenna port)	See Table 1-5 below.			
Sensitivity, typical (dBm at antenna port, PER<10%)	Modulation Level*	Sensitivity (HW Rev. A)	Sensitivity (HW Rev. B)	Min. SNR
	1	-87 dBm	-89 dBm	6 dB
	2	-86 dBm	-88 dBm	7 dB
	3	-85 dBm	-86 dBm	9 dB
	4	-83 dBm	-84 dBm	11 dB
	5	-80 dBm	-81 dBm	14 dB
	6	-76 dBm	-77 dBm	18 dB
	7	-71 dBm	-73 dBm	22 dB
	8**	-69 dBm	-71 dBm	23 dB
Modulation	OFDM modulation, 64 FFT points; BPSK, QPSK, QAM16, QAM64			

* Modulation Level indicates the radio transmission rate and the modulation scheme. Modulation Level 1 is for the lowest radio rate and modulation scheme.

** Modulation Level 8 is supported only in unit with HW Revision B and above.

Series	HW Revision	Unit Type	Modulation Level			
			1-5	6	7	8
5.8 GHz	A	SU	21	21	21	NA
5.8 GHz	B	SU	21	20	19	17

900 MHz Radio specifications

Item	Description
Frequency	903 – 927 MHz ISM band
Operation Mode	Time Division Duplex (TDD)
Radio Access Method	FH-CDMA
Standard Compliance	FCC Part 15.247
Channel Bandwidth	2 MHz
Central Frequency Resolution	1 MHz
SU Antenna	<ul style="list-style-type: none"> ■ 10 dBi, 55°x 65°, V/HPOL outdoor pole or wall mountable antenna. ■ 7 dBi, 40°x 35°, V/HPOL indoor window or wall mountable antenna. ■ Other: See 3rd Party Antenna List in Alvarion web site (www.alvarion-usa.com) for additional Alvarion certified antennas.
AU Antenna	<ul style="list-style-type: none"> ■ 10 dBi, 55° x 65°, Flat Panel (V/HPOL) pole or wall mountable antenna. ■ Other: See 3rd Party Antenna List in Alvarion web site (www.alvarion-usa.com) for additional Alvarion certified antennas.

Table 1-6: 900 MHz Radio Specifications			
Item	Description		
Maximum Input Power (at antenna port)	-20 dBm		
Output Power (at antenna port)	SU: 24 dBm typical, control range 3 to 24 dBm in 1 dB steps AU: 23 dBm typical (min), 24.5 dBm max.		
Gross Bit Rate	1, 2, 3 Mbps		
Sensitivity, typical (dBm at antenna port, BER 10E-6)	<u>Gross Rate</u>	<u>SU Sensitivity</u>	<u>AU Sensitivity</u>
	1 Mbps	-90 dBm	-91 dBm
	2 Mbps	-84 dBm	-85 dBm
	3 Mbps	-77 dBm	-78 dBm
Modulation	GFSK modulation, 2, 4 8 modulation states (1, 2, 3 bits/symbol)		
Symbol Rate	1 Msymbol/sec		

Standards Compliance, General

Table 1-7: Standards Compliance, General		
Type	Standard	
EMC	BA2.4, BA900: FCC Parts 15.207, 15.209 VL: FCC Part 15, ETSI EN 300 489-1	
Safety	IEC 60 950 US/C (TUV), FCC 1.1307	
Environmental	Operation	ETS 300 019 part 2-3 class 3.2E for indoor units ETS 300 019 part 2-4 class 4.1E for outdoor units
	Storage	ETS 300 019-2-1 class 1.2E
	Transportation	ETS 300 019-2-2 class 2.3
Lightning protection (AU Antenna connection)	EN 61000-4-5, Class 3 (2kV)	
Radio	BA2.4, BA900: FCC Parts 15.247, 15.203 VL: FCC Part 15, ETSI EN 301 753 ,ETSI EN 301 021, ETSI EN 301 893 (2003-04)	

Mechanical

Table 1-8: Mechanical Specifications			
Unit	Structure	Dimensions	Weight (kg/lb)
Interface Unit	Metal box, wall or 2"-3" pole mountable	20.3 x 36.7 x 11.5 cm 8 x 14.5 x 4.5 in (excluding mounting plate)	4.4 / 9.7
SU-RA-2.4	Metal box plus an integral antenna in a plastic enclosure, 2"-3" pole mountable	30.6 x 30.6 x 7.2 cm 12 x 12 x 2.8 in	2.5 / 5.5
AU-RE-2.4, AU-RE-900	Metal box, 2"-3" pole mountable	30.6 x 12 x 4.7 cm 12 x 4.7 x 1.8 in	1.6 / 3.5
BreezeACCESS VL SU-ODU	Metal box plus an integral antenna in a cut diamond shape in a plastic enclosure, 2"-3" pole or wall mountable	43.2 x 30.2 x 5.9 cm 17 x 11.9 x 2.3 in	2.5 / 5.5

Electrical

Table 1-9: Electrical Specifications	
Unit	Details
General	110-240 VAC, 50-60Hz, 1.4A max Power consumption: <200W
Power to 2.4 GHz and 900 MHz outdoor units	12 VDC from the Interface Unit via the IF cables
Power to BreezeACCESS VL outdoor units	54 VDC from the Interface Unit via the Category 5 Ethernet cable

Connectors

Unit	Connector	Description
Interface Unit	SU-IF	TNC female jack, lightning protected
	AU-IF	TNC female jack, lightning protected
	SU (VL)	10/100 Base-T (RJ-45), in a weather protected service box.
	ETHERNET	10/100Base-T (RJ-45), in a weather protected service box.
	Power	UL/CSA listed power cable through a Heyco-Flex Straight Connector 8402 that fits ½” conduit. 15 ft. cord, 3 wires, un-terminated. Requires fused 3 wire, single phase service.
SU-RA-2.4	IF	TNC jack, lightning protected
AU-RE-2.4	ANT	N-Type female jack
AU-RE-900	IF	TNC jack, lightning protected
BreezeACCESS VL SU-ODU	INDOOR	10/100BaseT Ethernet (RJ-45), in a weather protected service box.

Environmental

Type	Unit	Details
Operating temperature	CX Interface Unit	-20° C to 55° C (-4° F to 131° F)
	Radio Units	-40° C to 55° C (-40° F to 131° F)
Operating humidity	100% RH Condensing	

Chapter 2 - Installation

In this Chapter

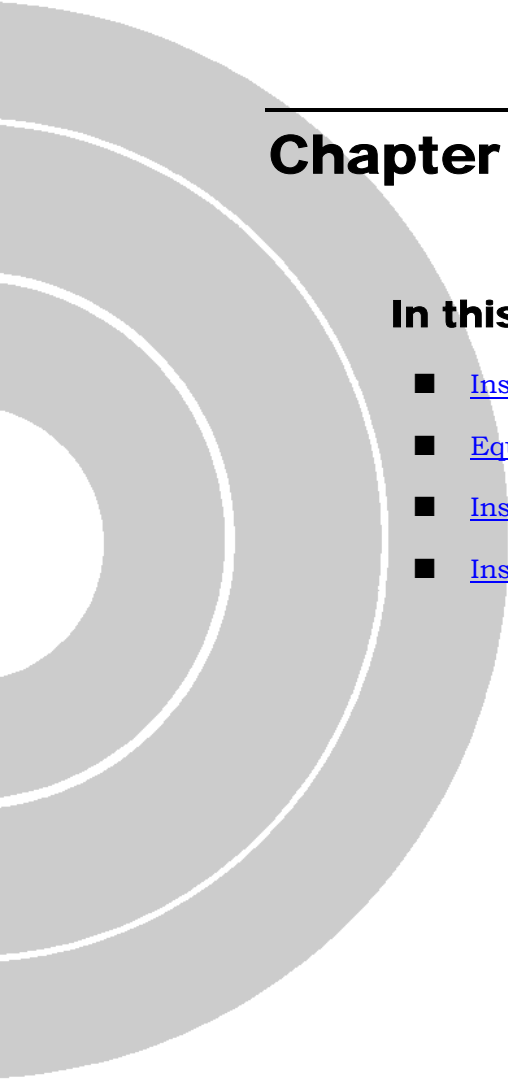
- [Installation Requirements](#), on page 2-2
 - [Equipment Location Guidelines](#), on page 2-5
 - [Installing the Radio Units](#), on page 2-8
 - [Installing the CX-IDU Interface Unit](#), on page 2-13
- 

Installation Requirements

This section describes all the supplies required to install the Cell Extender, and the items included in each installation package.

NOTE**Applicable to systems with a 900 MHz AU**

Before proceeding beyond this point and installing the Cell Extender, the spectrum survey should already be complete using the spectrum analysis tool provided with this equipment (special firmware). The results of the survey will identify the specific clear channels and polarization required to configure and operate the 900 MHz equipment. Refer to the BreezeACCESS Spectrum Analyzer User's Guide for detailed instructions on performing the survey. This step is important to ensure the best performance from the product.

Packing List for CX-BA2.4-BA2.4 Cell Extender

- CX-IDU Interface Unit with a 15 ft. (4.5 m) open-ended power cable
- Sun guard for the Interface Unit
- Mounting kit for the Interface Unit
- SU-RA-2.4 Radio Unit with an integrated 16 dBi antenna
- AU-RE-2.4 Radio Unit with a connection to an external antenna
- Two poll mounting kits for the radio units
- Two 98 ft. (30 m) RG 58 IF cables with TNC connectors
- RJ-45 Dual Monitor cable
- 5 ft. (1.5 m) LMR-400 Antenna cable with N-Type connectors
- A standard Monitor cable (for configuring the served SUs)
- Documentation CD

Packing List for CX-BA2.4-BA900 Cell Extender

- CX-IDU Interface Unit with a 15 ft. (4.5 m) open- ended power cable
- Sun guard for the Interface Unit
- Mounting kit for the Interface Unit
- SU-RA-2.4 Radio Unit with an integrated 16 dBi antenna
- AU-RE-900 MHz Radio Unit with a connection to an external antenna

- Two poll mounting kits for the radio units
- Two 98 ft. (30 m) RG 58 IF cables with TNC connectors
- RJ-45 Dual Monitor cable
- 5 ft. (1.5 m) LMR-400 Antenna cable with N-Type connectors
- A standard Monitor cable (for configuring the served SUs)
- Documentation and Utilities CD

Packing List for CX-VLA.B*-BA2.4 Cell Extender

* A.B is the frequency band of the BreezeACCESS VL unit. Currently available in the 5.8 GHz band.

- CX-IDU Interface Unit with a 15 ft. (4.5 m) open- ended power cable
- Sun guard for the Interface Unit
- Mounting kit for the Interface Unit
- SU-A-A.B-ODU with an integrated 16 dBi antenna
- AU-RE-2.4 Radio Unit with a connection to an external antenna
- Two poll mounting kits for the radio units
- 98 ft. (30 m) RG 58 IF cable with TNC connectors
- 98 ft. (30 m) Category 5 Ethernet cable kit
- RJ-45 Special Monitor cable
- 5 ft. (1.5 m) LMR-400 Antenna cable with N-Type connectors
- A standard Monitor cable (for configuring the served SUs)
- Documentation CD

Packing List for CX-VLA.B*-BA900 Cell Extender

* A.B is the frequency band of the BreezeACCESS VL unit. Currently available in the 5.8 GHz band.

- CX-IDU Interface Unit with a 15 ft. (4.5 m) open- ended power cable
- Sun guard for the Interface Unit
- Mounting kit for the Interface Unit
- SU-A-A.B-ODU with an integrated 16 dBi antenna
- AU-RE-900 Radio Unit with a connection to an external antenna

- Two poll mounting kits for the radio units
- 98 ft. (30 m) RG 58 IF cable with TNC connectors
- 98 ft. (30 m) Category 5 Ethernet cable kit
- RJ-45 Special Monitor cable
- 5 ft. (1.5 m) LMR-400 Antenna cable with N-Type connectors
- A standard Monitor cable (for configuring the served SUs)
- Documentation and Utilities CD

Additional Items Required for the CX Installation

The following items are also required for the installation of the Cell Extender:

- ½ inch conduit for the power cable
- 3 wire fused single phase 100 -240 VAC service (consult a licensed electrician to install)
- Outdoor category 5 Ethernet cable and connectors (if a local Ethernet connection is required)
- An approved AU antenna (see list of approved antennas in Tables 2-2, 2-3 and 2-4 on page 2-7)
- Grounding cables and other lightning protection materials according to specific installation requirements
- For configuring basic parameters – a portable PC with Terminal Emulation software (connected to the equipment using the appropriate Monitor cable)
OR
A portable PC with Ethernet NIC, an Ethernet cable (straight) and Telnet software (or BreezeCONFIG ACCESS Configuration Utility). Refer to for more details regarding applicable methods of connecting to the equipment for parameters' configuration.
- Installation tools and materials, including appropriate means (e.g. poles) for installing the system components and antennas.

Equipment Location Guidelines

This section provides key guidelines for selecting the optimal installation locations for the various Cell Extender components.

WARNING



ONLY experienced installation professionals who are familiar with local building and safety codes and, wherever applicable, are licensed by the appropriate government regulatory authorities should install outdoor units and antennas.

Failure to do so may void the BreezeACCESS product warranty and may expose the end user or Service Provider to legal and financial liabilities. Alvarion and its resellers or distributors are not liable for injury, damage or regulation violations associated with the installation of Outdoor Units or antennas.

Select the optimal locations for the equipment using the following guidelines:

- Units should be installed in easily accessible locations to facilitate installation and testing.
- The higher the placement of the antennas, the better the achievable link quality. Locate the Cell Extender's antennas at least 20 cm (8 in.) away from each other or any other antenna.
- The AU's antenna should be installed as close as possible to the AU's outdoor unit to minimize loss in the RF cable. The antenna should be installed so as to provide coverage to all Subscriber Units within its service area.



NOTE



The Cell Extender equipment complies with the ETS 300 385 standard and is protected against secondary lightning strikes when the Radio Units and antenna are properly grounded according to the relevant country specific industry standards for protection of structures against lightning. The system complies with EN 61000 4 5 test level 3 (2kV).

IF Cables

The 2.4 GHz and 900 MHz Radio Units of the Cell Extender are connected to the Interface Unit via IF cables carrying both signals and power. The IF frequency is 440 MHz. The maximum permitted attenuation of the IF cable is 15dB at 440 MHz and the maximum permitted DC resistance (the sum of the DC resistance of the inner and outer conductors) is 1.5 ohms. This enables a cable length of up to 30m when using the standard RG 58 cable.

If longer cables are required, a cable with lower attenuation and/or DC resistance should be used.

Table 2-1 provides detailed information about common cables such as the RG 58 and RG 213. If the spectral environment is polluted with noise in the 440 MHz band, it is recommended that a higher quality double-shielded cable, such as the LMR 200, LMR 240 and LMR 400, be used. (These cables are manufactured by Times Communications).

Table 2-1: IF Cables					
Cable Type	RG 58	RG 213	LMR 200	LMR 240	LMR 400
Maximum Cable Length (m)	30	100	45	65	150

If you are using coaxial cables other than those listed above, consult the cable manufacturers' specification to ensure that the cable's attenuation at 440 MHz does not exceed 15dB, and its DC loss (center conductor plus shield) does not exceed 1.5 ohms.

Approved Antennas

Table 2-2: 2.4 GHz FCC Approved Antenna		
Antenna Model	Description	Part Number
SECT-17V-60	17 dBi, 60 degree sector antenna	925920
SECT-16V-90	16 dBi, 90 degree sector antenna	925921
UNI-16	16 dBi directional panel antenna	901916
UNI-24	24 dBi directional grid antenna	901924
UNI-9	9 dBi directional panel antenna	811909
OMNI-8-2.4-SC	8 dBi omni-directional antenna	811938

Description	Part Number
902-928 MHz, 10 dBi Panel Antenna, V/HPOL pole or wall mount, N_Type connector	999436

**NOTE**

Consult with Alvarion sales on the availability of other antennas for use with the CX or look on the Alvarion website for the “Alvarion Certified Third Party Antennas” list for antennas approved for use on the product but not sold through Alvarion.

**WARNING**

It is the responsibility of the professional installer to ensure that when using the outdoor antenna kits, only these antenna configurations shown in the table above are used along with the minimum cable lengths provided with the product. The use of any antenna other than those listed is expressly forbidden in accordance to FCC rules CFR47 part 15.204.

Installing the Radio Units

The following sections describe how to install the Radio Units, including pole mounting the units, and connecting the necessary cables.

Pole Mounting the Radio Unit

The Radio Unit can be mounted on a pole using one of the following options:

- Special brackets and open-ended bolts are supplied with each unit. There are two pairs of threaded holes on the back of the unit, enabling the special brackets to be mounted on diverse pole widths.
- Special grooves on the sides of the unit enable the use of metal bands to secure the unit to a pole. The bands must be 9/16 inches wide and at least 12 inches long. The metal bands are not included with the installation package.

Figure 2-1 shows the locations of the holes and band grooves on the back, top and bottom of the Outdoor Unit.

NOTE



Be sure to install the unit with the bottom panel, which includes the LED indicators, facing downward.

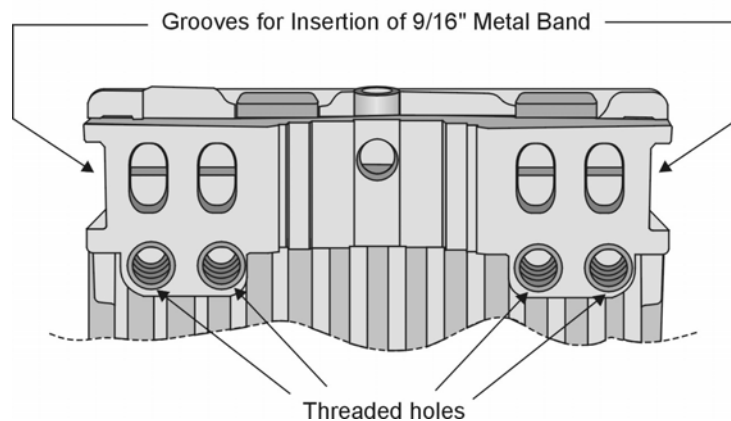

Figure 2-1: Threaded Holes/Grooves

Figure 2-2 illustrates the method of installing a Radio Unit on a pole, using the brackets and open-ended bolts.

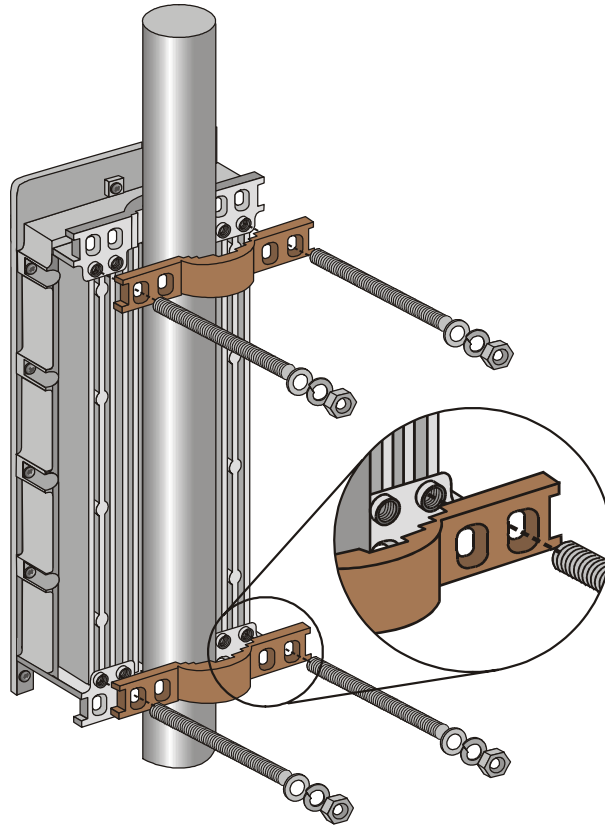

Figure 2-2: 3" Pole Installation of the Radio Unit Using Special Brackets



NOTE

Be sure to insert the open ended bolts with the grooves pointing outward, since these grooves enable you to use a screwdriver to fasten the bolts to the unit.

Connecting the Cables



To connect the ground cable:

1. Connect one end of a grounding cable to the ground terminal and tighten the ground screw firmly.
2. Connect the other end of the ground cable to a ground connection.



To connect the IF cable (900 MHz and 2.4 GHz equipment):

1. Connect one end of the coaxial IF cable to the IF connector on the bottom panel of the unit
2. Verify that the length of the IF cable is sufficient to reach the Interface Unit.
3. The IF cable connectors should be sealed properly to protect against rain and moisture.

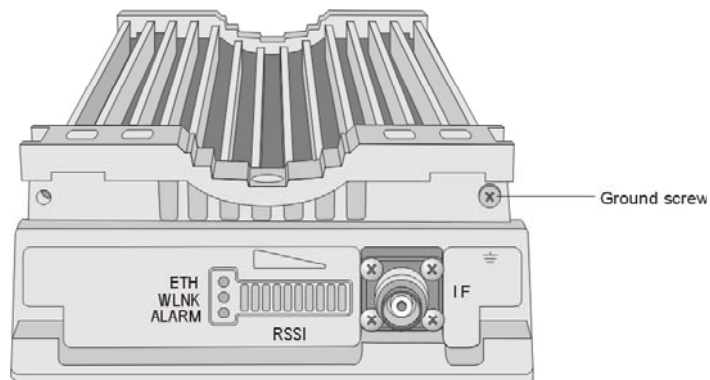

Figure 2-3: SU-RA-2.4 Bottom Panel

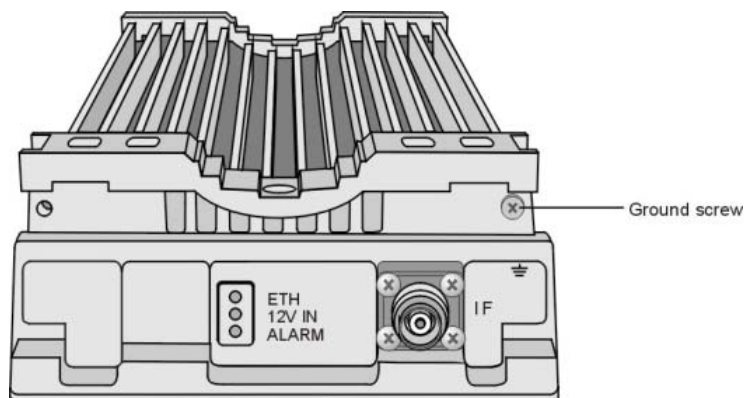
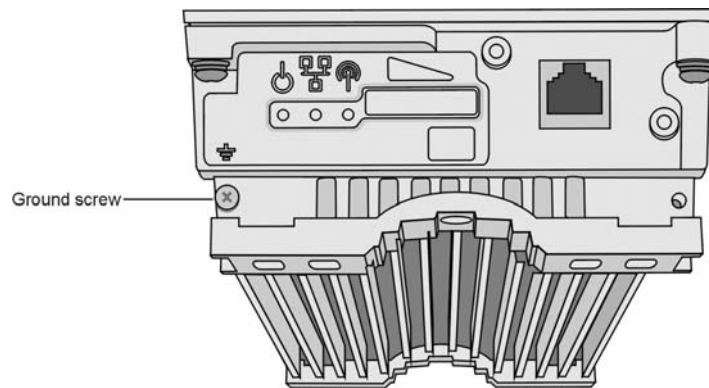

Figure 2-4: AU-RE-2.4, AU-RE-900 Bottom Panel



**Figure 2-5: BreezeACCESS VL ODU Bottom Panel
(without the service box)**



To connect the indoor-to-outdoor Ethernet cable (VL units with an installed service box):

1. Remove the two screws holding the service box to the outdoor unit and remove the service box.
2. Unscrew the top nut from the service box.
3. Route a straight, uncrimped Cat. 5 Ethernet cable (8-wire, 24 AWG) through both the top nut and the service box.



NOTE

The 8-wire cable should be shielded.

4. Insert and crimp the RJ-45 connector. Refer to [Appendix B](#) for instructions on preparing the cable.
5. Connect the Ethernet cable to the outdoor unit RJ-45 connector.
6. Replace the service box and then the top nut. Make sure that the external jack of the cable is well inside the service box to guarantee a good seal.
7. Route the cable to the location selected for the Interface Unit.



To connect the indoor-to-outdoor Ethernet cable (VL units with a service box supplied with the Ethernet cable):

1. Verify that the o-ring supplied with the cable kit is in place.
2. Connect the RJ-45 connector of the Ethernet cable to the outdoor unit.
3. Attach the service box to the unit. Tighten the top nut.
4. Route the cable to the location selected for the Interface Unit.



To connect the RF cable (AU):

1. Connect one end of the coaxial RF cable to the RF connector on the top panel of the unit.
2. Connect the other end of the RF cable to the antenna.
3. The RF connectors should be sealed properly to protect against rain and moisture

Installing the AU's Antenna

Locate the AU's antenna at least 20 cm (8 in.) away from the SU's antenna or any other antenna. Refer to the installation instructions included in the antenna kit. Use only the antennas stated in Tables 2-2, 2-3 and 2-5.



NOTE

Applicable to systems with a 900 MHz AU

Verify that you use the correct polarization according to the results of the spectrum analysis survey.



WARNING

ONLY experienced installation professionals who are familiar with local building and safety codes and, wherever applicable, are licensed by the appropriate government regulatory authorities should install outdoor units and antennas.

Failure to do so may void the BreezeACCESS product warranty and may expose the end user or Service Provider to legal and financial liabilities. Alvarion and its resellers or distributors are not liable for injury, damage or regulation violations associated with the installation of Outdoor Units or antennas.

Installing the CX-IDU Interface Unit

The following sections describe how to install the Interface Unit, including wall and poll mounting the unit, preparing the power cable and connecting the ground and IF / Ethernet cables.

NOTE Applicable to CX-BA2.4-BA2.4 and CX-BA2.4-BA900



The mechanical structure of current Interface Units of CX-BA2.4-BA2.4 and CX-BA2.4-BA900 is slightly different from the mechanical structure of Interface Units of other Cell Extenders as described throughout the manual. Refer to Appendix C for more details on the applicable differences.

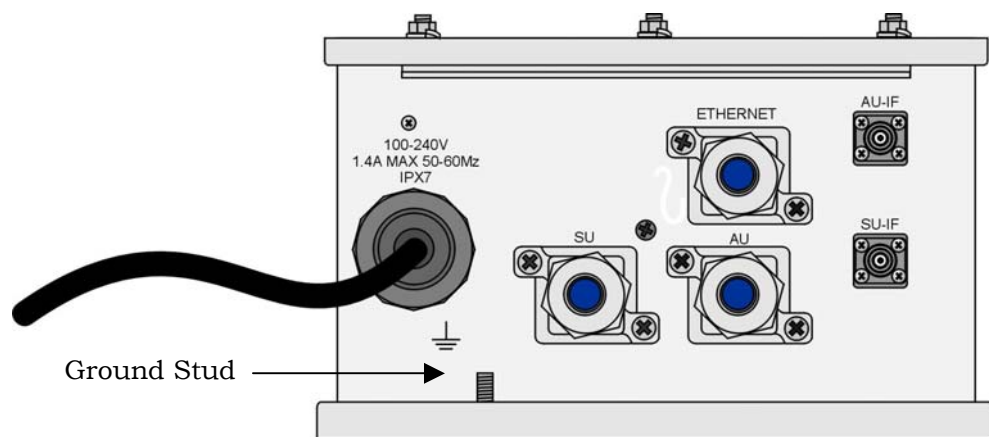

Figure 2-6: Interface Unit Bottom Panel

NOTE



1. The unit is shown with all connectors installed, which is true for CX-BA2.4-BA2.4 and CX-BA2.4-BA900. In system with a VL radio unit(s), blank cover(s) are installed in place of the SU-IF and/or AU-IF connectors.
2. The unit is shown without the strings that secure the service boxes' bodies and top nuts to the unit.

Table 2-4: CX-IDU's Connectors	
Connector	Description
AU-IF	A connection to the radio unit of IF-based AU. Does not exist in system with a BreezeACCESS VL AU.
SU-IF	A connection to the radio unit of IF-based SU. Does not exist in systems with a BreezeACCESS VL SU.
Ethernet	A 10Base-T 10 Mbps, half duplex connection to local Ethernet equipment, protected by a weather-proof service box. Dual-mode functionality with 2.4 GHz or 900 MHz units - functions also as a connection to monitor.
AU	Future option for connecting a BreezeACCESS VL AU-ODU. Cell Extenders with BreezeACCESS VL AU are not available currently.
SU	A 10/100Base-T connection to the ODU of BreezeACCESS VL SU, protected by a weather-proof service box.

Wall Mounting the Interface Unit

The Interface Unit must be installed with the bottom panel, which includes the connectors, facing downward.

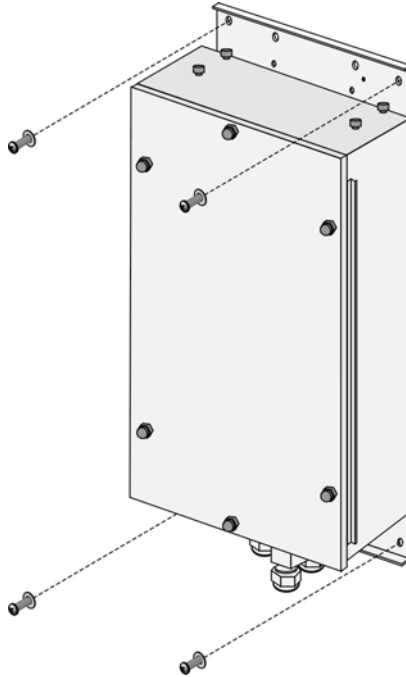

Figure 2-7: Wall Mounting the Interface Unit

The Interface Unit can be secured to a wooden wall using 4 screws or to a concrete wall using 4 masonry anchors and suitable bolts.

If the unit is exposed to direct sunlight, the Sun Guard must be attached to the top of the unit to prevent overheating.

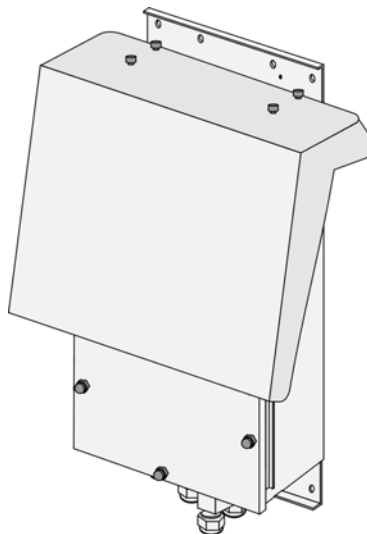

Figure 2-8: Interface Unit with Sun Guard

Pole Mounting the Interface Unit

The Interface Unit must be installed with the bottom panel, which includes the connectors, facing downward.

Special brackets and open-ended bolts are supplied with each unit. There are two pairs of threaded holes on the back of the unit, enabling the special brackets to be used for mounting the unit on up to 3" polls.

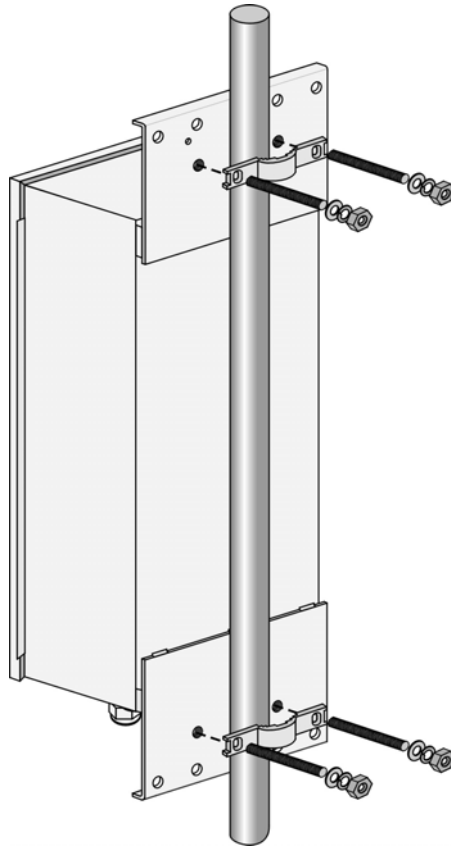

Figure 2-9: Pole Mounting the Indoor Unit



NOTE

Be sure to insert the open ended bolts with the grooves pointing outward, since these grooves enable you to use a screwdriver to fasten the bolts to the unit.

If the unit is exposed to direct sunlight, the Sun Guard must be installed to prevent overheating.

Preparing the Power Cord



CAUTION

Electric Shock Hazard. The power plug should be connected only by a licensed electrician.

The power cord should be environmentally protected with a ½ inch conduit to the electrical junction box or breaker panel. If connecting to a standard AC receptacle is required, attach a power plug that meets local electrical regulations.

NOTE



The color codes of the power cable are as follows:

Black	Phase	~
Grey/White	Neutral	0
Yellow/Green	Ground	⊕

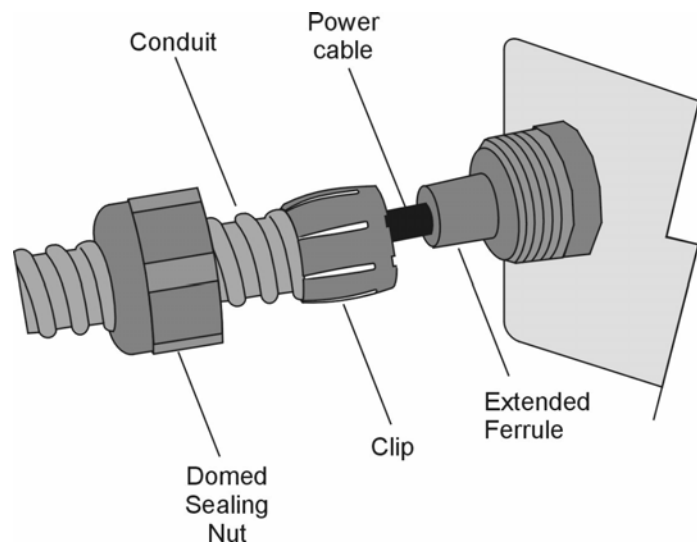

Figure 2-10: Preparing the Power Cord



To prepare the power cord:

1. Release the domed sealing nut and the special clip of the power cord protective connector.
2. Push the ½ inch conduit over the power cable and through the domed sealing nut until it reaches the end of the special clip. Continue pushing it onto the ferrule, and then tighten the domed sealing nut.

Connecting the Cables



To connect the ground cable:

1. Connect one end of the ground cable to the ground stud.
2. Connect the other end of the ground cable to a suitable ground connection.



To connect the IF cables (900 MHz and 2.4 GHz equipment):

1. Connect the IF coaxial cable(s) between the radio unit and the appropriate connector (SU-IF or AU-IF) located on the bottom panel of the unit.
2. The IF cable connectors should be sealed properly to protect against rain and moisture.



CAUTION

Do not connect or disconnect the IF cables while the Interface unit is powered.



To connect the indoor-to-outdoor Ethernet cable (for connecting to BreezeACCESS VL units):

1. Remove the two screws holding the applicable service box (marked SU) to the unit and remove the service box.
2. Unscrew the top nut from the service box. If there is a sealing metal disk inside, remove it.
3. Route the uncrimped end of the indoor-to-outdoor Cat. 5 Ethernet cable (8-wire, 24 AWG) through both the top nut and the service box.



NOTE

The 8-wire cable should be shielded.

4. Insert and crimp the RJ-45 connector. Refer to [Appendix B](#) for instructions on preparing the cable.
5. Connect the Ethernet cable to the RJ-45 connector.
6. Replace the service box and then the top nut. Make sure that the external jack of the cable is well inside the service box to guarantee a good seal.

**NOTE**

In unused Ethernet connection service boxes, a sealing metal disk must be in place inside the top nut to ensure proper protection against rain and moisture.

**To connect the power cable:**

1. Connect the power cable to the AC mains.
2. Seal the power cable conduit at the AC mains end to prevent the entry of insects.

**To connect the Ethernet port to a local Ethernet equipment****NOTE**

The Ethernet port of the local Ethernet equipment, such as a PC or a hub, must be configured manually to operate at 10 Mbps, half-duplex. Auto-Negotiation may not work.

1. Remove the two screws holding the ETHERNET service box to the unit and remove the service box.
2. Unscrew the top nut from the service box. If there is a sealing metal disk inside, remove it.
3. Route the uncrimped end of a Cat. 5 Ethernet cable (8-wire, 24 AWG) through both the top nut and the service box.



NOTE

The 8-wire cable should be shielded.

4. Insert and crimp the RJ-45 connector. Refer to [AppendixA](#) for information on different wiring schemes. Refer to [AppendixB](#) for instructions on preparing the cable.
5. Replace the service box and then the top nut. Make sure that the external jack of the cable is well inside the service box to guarantee a good seal.
6. Connect the other end of the Ethernet cable to your equipment.



NOTE

In unused Ethernet connection service boxes, a sealing metal disk must be in place inside the top nut to ensure proper protection against rain and moisture.

Chapter 3 - Commissioning

About this Chapter

- [Configuring Basic Parameters](#), on page 3-2
- [Aligning the SU's Antenna](#), on page 3-14
- [Configuring the Transmit Power of the AU-RE-2.4](#), on page 3-16
- [Verifying Proper Operation](#), on page 3-17

Configuring Basic Parameters

After completing the installation process, as described in the preceding chapter, the basic parameters must be configured to ensure that the unit operates correctly. Once the basic parameters have been configured, additional parameters can be remotely configured via the Ethernet port or the wireless link using Telnet or SNMP management, or by loading a configuration file.

Local configuration of parameters can be performed using any of the following methods:

- Accessing the Monitor program via the Monitor port – applicable only to 900 MHz and 2.4 GHz units.
- Accessing the Monitor program via Telnet.
- Using the BreezeCONFIG utility for the applicable product line (BreezeCONFIG ACCESS for 900 MHz and 2.4 GHz units, BreezeCONFIG for BreezeACCESS VL for BreezeACCESS VL units)

Accessing the Monitor Program



To access the Monitor Program using the Monitor cable (900 MHz and 2.4 GHz units):

To configure 900 MHz and 2.4 GHz units, use the special Monitor cable supplied with the Cell Extender to connect the Ethernet connector of the unit to the COM port of a PC running a terminal emulation program.

The Dual Monitor cable supplied with equipment where both AU and SU have a Monitor port (CX-BA2.4-BA2.4, CX-BA2.4-BA900) have two 9-pin D-type plugs. One plug connects to the SU interface module inside the unit and the other plug connects to the AU module.

The Special Monitor cable supplied with equipment where only the AU has a Monitor port (2.4 GHz or 900 MHz AU) has one 9-pin D-type plug that connects to the AU interface module inside the unit.

1. Run a terminal emulation program, such as HyperTerminal™.
2. Set the communication parameters as shown in Table 3-1.
3. Press Enter. The Select Access Level menu is displayed.

4. Select the required access level, depending on your specific access rights. A password entry request is displayed.
5. Enter your password and press Enter. The Main Menu is displayed.

Table 3-1: Monitor Port Communication Parameters	
Parameter	Value
Baud Rate	9600
Data Bits	8
Stop Bits	1
Parity	None
Flow Control	Xon/Xoff
Connector	Connected COM port

NOTE

Following three unsuccessful login attempts (using incorrect passwords) from either the Monitor port or via Telnet, the monitor program is blocked for several minutes. To enable access to the monitor program during that time, the unit must be reset via SNMP or by disconnecting/reconnecting power.

**To access the Monitor Program locally using Telnet:**

1. Connect a PC to the Ethernet port using a crossover cable.
2. Run any BreezeCONFIG utility and use the Set IP feature to configure the IP Addresses of the two units. The MAC addresses are marked on the Interface Unit. In BreezeACCESS VL units, the MAC address is also marked on the ODU.
3. Configure the PC's IP parameters to enable connectivity with the unit.
4. Run the Telnet program. The Select Access Level menu is displayed.
5. Select the required access level, depending on your specific access rights. A password entry request is displayed.
6. Enter your password and press Enter. The Main Menu is displayed.

NOTE

If the Telnet session is not terminated properly, for example, if you simply close the window, the monitor program is blocked for several minutes. To enable access to the monitor program during that time, the unit must be reset via SNMP or by disconnecting/reconnecting power.

**Using the BreezeCONFIG to set an IP address:**

The Set IP Address feature simplifies the procedure for defining IP address information for newly added units that are still defined by their default IP settings. This feature can only be used if the management station is on the same Ethernet segment as the unit and not behind a router.



1. In the toolbar, click , or select **Set IP** from the Tools menu. The *Set IP* window is displayed, as shown below.

MAC Address	00	20	D6	00	00	00
IP Address	199	203	142	0		
Subnet Mask	255	255	255	000		
Default Gateway	000	000	000	000		

OK Cancel

Figure 3-1: Set IP Window

2. In the **MAC Address** field, enter the unit's MAC address.
3. In the **IP Address field**, enter the required IP address for the unit.
4. In the **Subnet Mask** field, enter the required subnet mask.
5. In the **Default Gateway** field, enter the unit's default gateway.
6. Click on  to activate the changes. The unit will be reset automatically.

**NOTE**

In order to “see” the unit after assigning the IP address, the assigned IP address must be on the same IP subnet as the station running the BreezeCONFIG utility.

The Basic Parameters

The Basic Configuration menu includes all the parameters necessary for the initial installation and operation of the Cell Extender components. In many installations, most of these parameters should not be changed from their default values. The basic parameters and their default values are listed in Tables 3-2 to 3-4. Once the basic parameters are configured, the unit must be reset in order to activate the new configuration.

Refer to the applicable System Manual for more information on the parameters.

Basic Parameters in 2.4 GHz Units (SW Version 4.5)

NOTE



Units running SW version 4.5 that use FCC hopping standard can be configured to operate in HDM mode. This enables better performance in high interference environments by providing the ability to configure the units to use only interference-free channels, including hopping synchronization support.

WARNING



For compliance with IC&FCC regulations, the AU and SU units in HDM mode must be configured to ensure that the output power does not exceed 19 dBm. In legacy units that were upgraded from firmware version 4.3 or lower, it is mandatory to attach the new IC&FCC HDM ID label to the unit. The HDM ID label is only available from Alvarion when ordering the Firmware 4.5 Upgrade Kit.

The maximum output power levels for compliance with the applicable IC&FCC regulation are listed below:

Table 3-2: Maximum Output Power for IC&FCC Compliance		
Operation Mode	Max Output Power	IC&FCC ID Label
FH (Non HDM)	26 dBm	FH Mode
HDM	19 dBm	FH Mode & *HDM Mode * IC 2514A-IF24SYNC FCC ID LKT-IF-24-SYNC

Table 3-3: Basic Parameters in 2.4 GHz Units		
Parameter	Default Value	Comment
IP Address	10.0.0.1	
Subnet Mask	255.0.0.0	
Default Gateway Address	0.0.0.0	
DHCP Options	Disable	
Access to DHCP	SU: From Wlan Only AU:From Ethernet Only	

Table 3-3: Basic Parameters in 2.4 GHz Units		
Parameter	Default Value	Comment
ESSID	ESSID1	The ESSID of the SU module must be the same as the ESSID of the Base Station AU. In CX-BA2.4-BA-2.4 DO NOT configure the ESSID of the SU with the Operator ESSID. A different ESSID must be configured in the AU module.
Operator ESSID Option (AU)	Enable	
Operator ESSID (AU)	ESSID1	Modify this parameter to the same Operator ESSID of the other AUs. If you are not using this parameter, where the Operator ESSID Option is disabled, change the value to something other than the default.
Hopping Set (AU)		Not applicable if HDM Mode is enabled. In CX-BA2.4-BA-2.4, must be the same as configured for the Base Station AU.
Hopping Sequence (AU)		Not applicable if HDM Mode is enabled. In CX-BA2.4-BA-2.4, must differ from the Hopping Sequence configured for the Base Station AU.
HDM Mode (AU)	Disable	Applicable only to US FCC hopping standard.

Table 3-3: Basic Parameters in 2.4 GHz Units		
Parameter	Default Value	Comment
Flexible Hopping Definition (AU) (Add/Remove Frequencies)	2402	Applicable only if HDM Mode is enabled.
Scrambling Mode (AU)	Enhanced	Applicable only if HDM Mode is enabled.
Manual Sequence Definition (AU)		Applicable only when HDM Mode is enabled and Scrambling Mode is configured to Manual Scrambling.
Spanning Factor (AU)	1	Applicable only if HDM Mode is enabled and Scrambling Mode is configured to Enhanced Scrambling with 7 or more frequencies.
Transmit Power Control	15	For compliance with IC&FCC regulations, in HDM Mode the output power should not exceed 19 dBm. For AU, the EIRP should not exceed 36 dBm. For more details refer to Configuring the Transmit Power of the AU-RE-2.4 on page 3-16.
ATPC Option	SU: Enable AU: Disable	
Best AU Support (SU)	Disable	
Preferred AU MAC Address (SU)	00-00-00-00-00-00 (none)	Applicable only when Best AU Support is enabled
Scanning Mode	Active	
VLAN Link Type	Hybrid	

Table 3-3: Basic Parameters in 2.4 GHz Units		
Parameter	Default Value	Comment
VLAN ID-Management	65535	
Authentication Algorithm	Open System	Can be changed to Shared Key only after configuring the WEP Key and the applicable Default Key ID.
Default Key ID	1	
WEP Key 1-4	0000000000 (none)	
Encryption Seed	7	
Encryption Polynom Index	0	

**NOTE**

Once the basic parameters are configured, the unit must be reset in order to activate the new configuration.

Basic Parameters in 900 MHz Units (SW version 4.5)

NOTE



For compliance with FCC rules, the power input to the 900 MHz antenna of the CX should not exceed 23dBm. The Transmit Power Control should be set to 1 (delivering 24.5dBm power output) only when using a longer RF cable with an attenuation of 1.5dB at least, or when using an external Band-pass filter to compensate for the power loss in the filter. Such a filter may be required if the equipment is located near a very strong transmitter using frequencies that are close to the frequencies used by the BreezeACCESS equipment.

Parameter	Default Value	Comment
IP Address	10.0.0.1	
Subnet Mask	255.0.0.0	
Default Gateway Address	0.0.0.0	
DHCP Options	Disable	
Access to DHCP	From Ethernet Only	
ESSID	ESSID1	
Operator ESSID Option	Enable	
Operator ESSID	ESSID1	
HDM Mode	Disable	
Flexible Hopping Definition	915 MHz	According to the spectrum analysis survey. Not applicable when the Scan Entire Band is enabled.
Scrambling Mode	Enhanced	
Manual Sequence Definition		Applicable only when Scrambling Mode is configured to Manual Scrambling.
Spanning Factor	1	Applicable only for Enhanced Scrambling with 7 or more frequencies.

Table 3-4: Basic Parameters in 900 MHz AUs		
Parameter	Default Value	Comment
Transmit Power Control	0	See note above.
VLAN Link Type	Hybrid	
VLAN ID-Management	65535	
Authentication Algorithm	Open System	Can be changed to Shared Key only after configuring at least one WEP Key
WEP Key 1-4	0000000000 (none)	
Encryption Seed	7	
Encryption Polynom Index	0	

**NOTE**

Once the basic parameters are configured, the unit must be reset in order to activate the new configuration.

Basic Parameters in BreezeACCESS VL SU (SW Version 2.0)

Ethernet Port Negotiation Mode

WARNING

In mixed bands Cell Extenders with a BreezeACCESS VL SU, the Ethernet Port of the BreezeACCESS VL SU must be configured to operate in 10 Mbps, Half-Duplex mode.

Table 3-5: Basic Parameters in BreezeACCESS VL SU		
Parameter	Default Value	Comment
IP Address	10.0.0.1	
Subnet Mask	255.0.0.0	
Default Gateway Address	0.0.0.0	
DHCP Options	Disable	
Access to DHCP	From Wireless Only	
ESSID	ESSID1	
Sub Band Select	1	Applicable only if more than one Sub Band is available.
Frequency Subset Definition	A (All)	The list of frequencies is in accordance with the Sub Band.
Tx Power for Modulation Levels 1 to 5	Depend on HW revision, unit type and Sub Band.	Tx Power cannot be higher than the applicable Maximum Tx Power parameter.
Tx Power for Modulation Level 6		
Tx Power for Modulation Level 7		
Tx Power for Modulation Level 8		

Table 3-5: Basic Parameters in BreezeACCESS VL SU		
Parameter	Default Value	Comment
Maximum Tx Power for Modulation Levels 1 to 5	Depend on HW revision and Sub Band	Max Tx Power cannot be higher than the upper limit according to the Sub Band in use.
Maximum Tx Power for Modulation Level 6		
Maximum Tx Power for Modulation Level 7		
Maximum Tx Power for Modulation Level 8		
Antenna Gain (units with external antenna)	According to the antenna supplied with the unit and the Sub Band.	If set to "Not Set Yet", must be configured according to actual value, taking into account cable's attenuation.
ATPC Option	Enable	
Best AU Support	Disable	
Preferred AU MAC Address	00-00-00-00-00-00 (none)	Applicable only when Best AU Support is enabled
VLAN Link Type	Hybrid	
VLAN ID-Management	65535	
Authentication Algorithm	Open System	Availability of security parameters depends on support according to the country code.
Data Encryption Option	Disable	
Security Mode	WEP	
Default Key	Key 1	
Key 1 to Key 4	00.....0 (32 zeros, meaning no key)	

NOTE

Once the basic parameters are configured, the unit must be reset in order to activate the new configuration.

Aligning the SU's Antenna

The SNR bar display is located on the bottom panel of the outdoor unit. The 8 green LEDs are used for indicating the quality of the received signal. The higher is the number of green LEDs that are on, the better the quality of the received signal. This section describes how to align the antenna using the SNR bar display.

NOTE



Antenna alignment using the SNR bar display is possible only after the SU is associated with an Access Unit. The associated Access Unit must be operational and the basic SU's parameters must be correctly configured. If not, the unit will not be able to synchronize with the Access Unit. As the SNR measurement is performed on received frames, its results are meaningless unless the SU is associated with an Access Unit.



To align the SU's antenna:

1. Align the antenna, which is integrated into the front side of the radio unit, by pointing it in the general direction of the Base Station.
2. Verify that the power indication of the unit is **On**.
3. Verify that the WLNK LED of the unit is **On**, indicating that the unit is associated with an Access Unit. If the WLNK LED is **Off**, check that the basic parameters are correctly configured. If the unit is still not associated with the AU, improve the quality of the link by changing the direction of the antenna or by placing the antenna at a higher or alternate location.
4. Ensure that the front of the antenna is always facing the Base Station. However, in certain conditions, such as when the line of site to the Base Station is hampered, better reception may be achieved using a reflected signal. In this case, the antenna is not always directed toward the Base Station.
5. Rotate the antenna until the maximum SNR reading is achieved, where at least 1 green LED is on: If you encounter prolonged difficulty in illuminating the minimum required number of green LEDs, try to improve the reception quality by placing the antenna at a higher point or in an alternate location.
6. Secure the unit firmly to the pole.

**NOTE**

If you are having difficulties in obtaining a good RSSI, since the RSSI bar indicator is not precise, it is recommended that you use the Continuous Link Quality Display test for more precise alignment of the antenna.

**NOTE****Applicable only to BreezeACCESS VL SU**

In some cases, the antenna of the BreezeACCESS VL SU may need to be tilted to ensure that the level at which the SU receives transmissions from the AU (and vice versa) is not too high. As a rule of thumb, if the SU is located at a distance of less than 300 meters from the AU, it is recommended to up-tilt the antenna by approximately 10° to 15°. To guarantee a safety margin from the saturation level (received signal of –40dBm at the antenna port), the SNR should not be higher than 50dB. The orange LED of the SNR bar indicates that the SNR is higher than 50dB.

Configuring the Transmit Power of the AU-RE-2.4

The transmitted output power of the AU-RE-2.4 should be adjusted in the following cases:

- If there is a need to cover a relatively small area while minimizing the interference with the operation of units in neighboring cells.
- According to the FCC rules 15.247 (3), when operating the equipment in a multi_point system, the RF output power must be adjusted according to the gain of the antenna to limit the EIRP to a maximum of 36 dBm.

Table 3-6 displays the required value of the Transmit Power Control parameter for FCC approved antennas.

NOTE

According to FCC Rule 15.204 ©, only antennas authorized as part of the FCC grant may be used with this product.



For compliance with IC&FCC requirements, the maximum allowed output power in units operating in HDM Mode is 19 dBm. Therefore, when using an antenna with a net gain of 17 dBi or lower, the Transmit Power Control parameter should be set to the maximum value for an output power that does not exceed 19 dBm. These values are identified clearly in the appropriate locations in the tables.

Antenna	Net Gain*	Transmit Power Control Parameter	Output Power to Antenna Port
SECT 17V-60	16.5	10	19
SECT 16V-90	17.5	9	17
UNI-16	15.5	10	19
UNI-24	23.5	7	12
UNI-9	7.5	15 (10 for HDM)	26.5 (19 for HDM)
OMNI-8	7.5	15 (10 for HDM)	26.5 (19 for HDM)

* The net gain of the antenna kit includes the loss of the RF cable included in the kit (if applicable).

Verifying Proper Operation

The following sections describe how to verify the correct functioning of the various unit, Ethernet connections and data connectivity.



LED Indicators

To verify the correct operation of the units, examine the LED indicators located on the bottom panel of the Radio Units.

The following tables list the provided LEDs and their associated indications.

Table 3-7: SU-RA-2.4 LEDs		
Name	Description	Functionality
ETH	Ethernet activity indication	Off – No traffic activity detected on the Ethernet port Blinking – Data received from or transmitted to the Ethernet port
WLNK	Wireless Link Activity Indicator	Blinking – Packets received from the wireless link Off – No reception of packets from the wireless link
ALARM	Alarm Indication	On – A problem with the power amplifier or in the locking process of any of the synthesizers Off – Normal operation

Table 3-8: AU-RE-2.4, AU-RE-900 LEDs		
Name	Description	Functionality
ETH	Ethernet activity indication	Off – No traffic activity detected on the Ethernet port Blinking – Data received from or transmitted to the Ethernet port
12V IN	12 VDC Power Supply Indication	On – 12 VDC power is supplied to the unit Off – 12 VDC power is not available
ALARM	Alarm Indication	On – A problem with the power amplifier or in the locking process of any of the synthesizers Off – Normal operation

Table 3-9: BreezeACCESS VL SU-ODU LEDs			
Name		Description	Functionality
W-LINK		Wireless Link Indicator	<ul style="list-style-type: none"> ■ Green – Unit is associated with an AU, no wireless link activity ■ Blinking Green – Data received or transmitted on the wireless link. Blinking rate is proportional to wireless traffic rate ■ Off – Wireless link disabled
status		Self-test and power indication	<ul style="list-style-type: none"> ■ Green – Power is available and self-test passed. ■ Blinking Amber – Testing (not ready for operation) ■ Red – Self-test failed – fatal error
ETH		Ethernet activity/ connectivity indication	<ul style="list-style-type: none"> ■ Green – Ethernet link between the indoor and outdoor units is detected, no activity ■ Blinking Green – Ethernet connectivity is OK, with traffic on the port. Blinking rate proportional to traffic rate. ■ Red – No Ethernet connectivity between the indoor and outdoor units.
SNR BAR (SU-RA)		Received signal strength Indication	<ul style="list-style-type: none"> ■ Red LED: Signal is too low (SNR<4dB) ■ 8 green LEDs: Quality of the received signal ■ Orange LED: Signal is too high (SNR>50dB)



A

Appendix A - Wiring 10/100Base-T Jacks



Connecting a PC to the CX



To connect a PC to the CX, use a straight-through cable, as shown in Figure A-1:

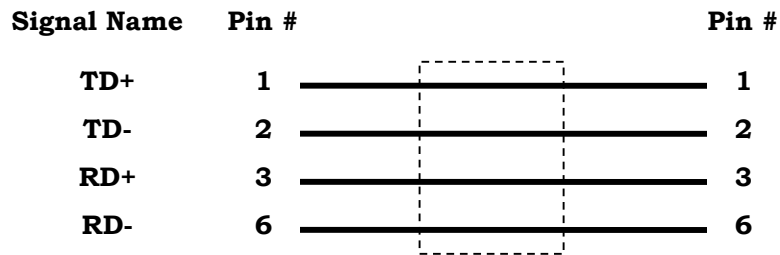

Figure A-1: Straight-Through Cable Connection

Connecting a Hub to the CX



To connect a hub to the CX, use a crossover cable, as shown in Figure A-2:

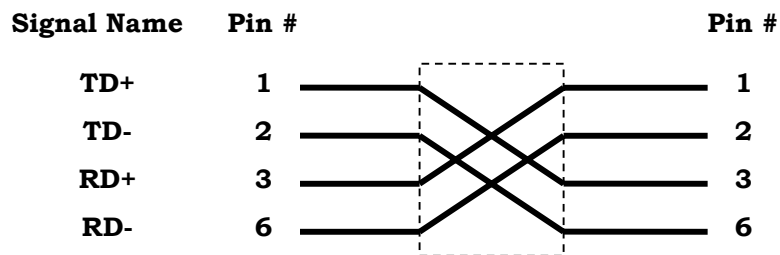

Figure A-2: Crossover Cable Connections

To establish which pin is pin number 1, hold the cable so that the end of the plastic RJ45 tip, which is the part that inserts first into the wall jack, is facing away from you. Flip the clip so that the copper side faces up. The springy clip is facing down and parallel to the floor. When looking down on the coppers, pin 1 is on the far left.



B

Appendix B - Preparing the Indoor to Outdoor Ethernet Cable



The Indoor-to-Outdoor cable provides pin-to-pin connection on both ends.

Figure B-1 shows the wire pair connections required for the Indoor-to-Outdoor cable.

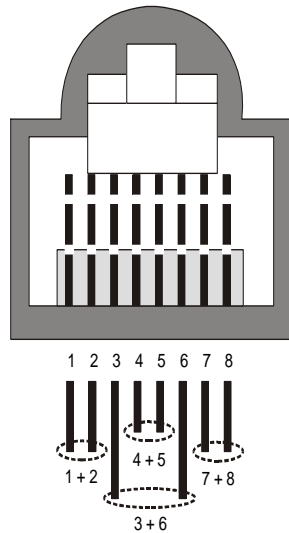

Figure B-1: Ethernet Connector Pin Assignments

The color codes used in cables supplied by Alvarion with crimped connectors are as listed in the following table:

Table B-1: Cable Color Codes	
Wire color	Pin
Blue	1
Blue/white	2
Orange	3
Orange/white	6
Brown	4
Brown/white	5
Green	7
Green/white	8

Use a crimp tool for RJ-45 connectors to prepare the wires, insert them into the appropriate pins and use the crimp tool to crimp the connector. Make sure to do the following:

1. Remove as small a length as possible of the external jacket. Verify that the external jacket is well inside the service box to ensure good sealing.
2. Take back the shield drain wire before inserting the cable into the RJ-45 connector, to ensure a good connection with the connector's shield after crimping.

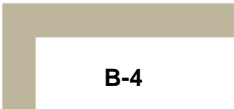



C

Appendix C - Mechanical Structure
and Installation of CX-IDU units
Currently supplied with CX-BA2.4-
BA-2.4 and CX-BA2.4-BA900

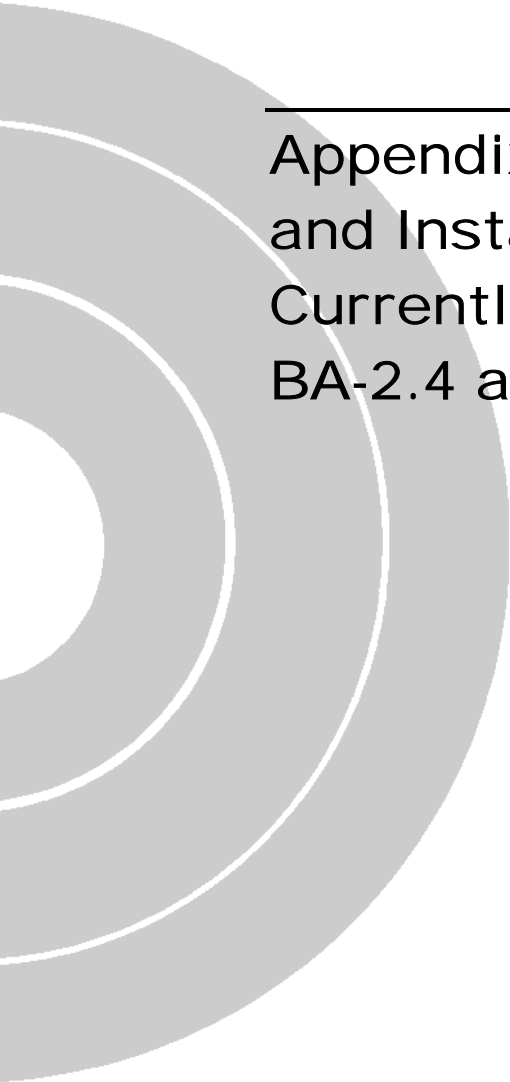

Mechanical and Environmental Specifications

Table 3-2: Mechanical and Environmental Specifications	
Type	Specifications
Mechanical	11 x 9 x 4.3 in, 13 lbs. 28 x 23 x 11 cm, 5.9 kg
Operating temperature	14° F to 131° F -10° C to 55° C

Installation

The following sections describe how to install Interface Unit of currently supplied CX-BA2.4-BA2.4 and CX-BA2.4-BA900.

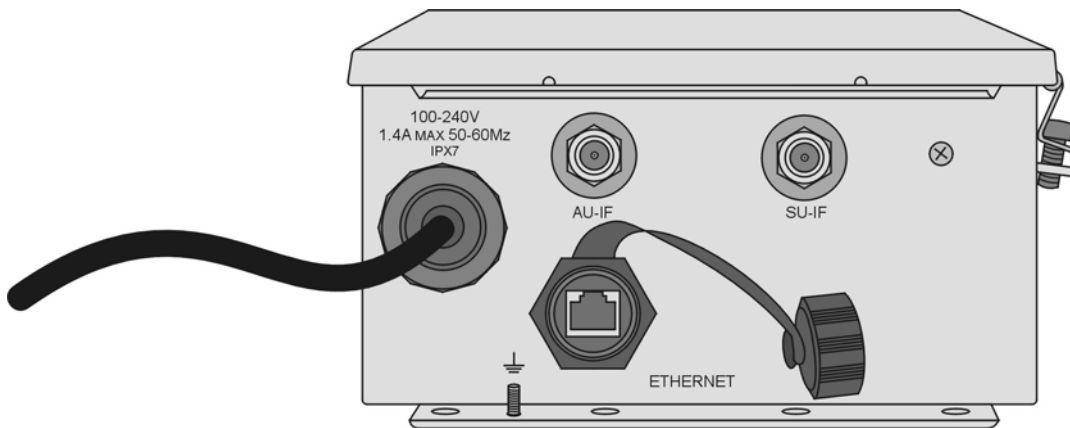

Figure C-1: Interface Unit Bottom Panel

When installed on a wall, the Interface Unit must be installed with the bottom panel, which includes the connectors, facing downward.

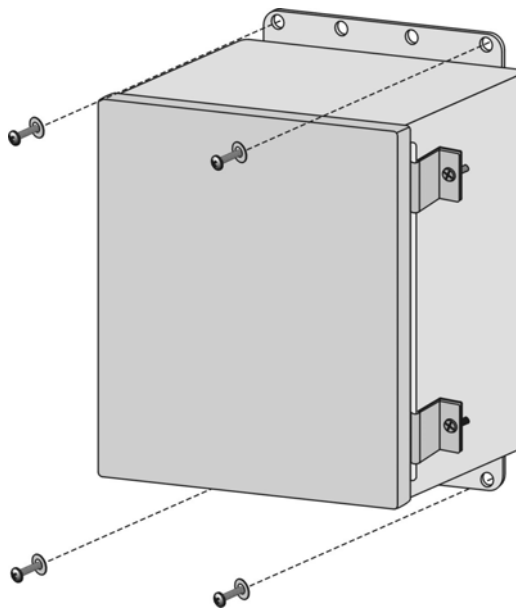

Figure C-2: Wall Mounting the Interface Unit

The Interface Unit can be secured to a wooden wall using 4 screws or to a concrete wall using 4 masonry anchors and suitable bolts.

If the unit is exposed to direct sunlight, the Sun Guard must be installed to prevent overheating. Before the screws or bolts are firmly secured, place the Sun Guard so that it is properly secured between the unit and the wall.

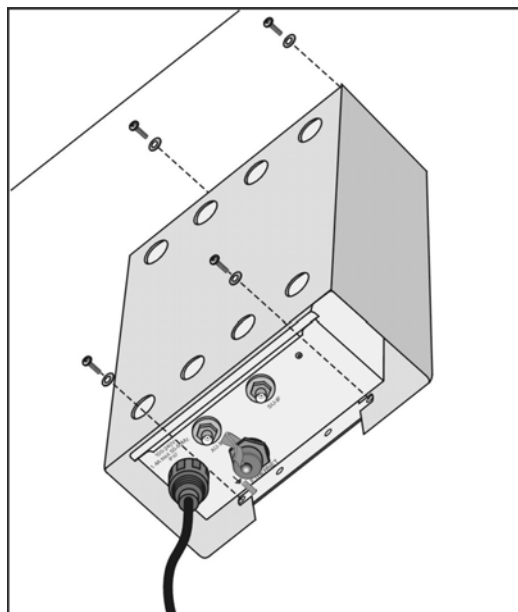

Figure C-3: Interface Unit with Sun Guard

